

GPB INSTALLATION SUGGESTIONS

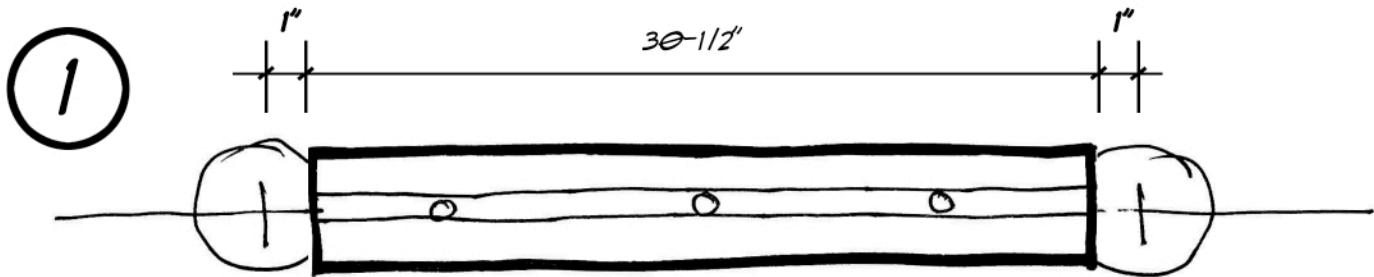

LOCATE THE POSITION OF THE GPB THEN DRAW A CENTER LINE. SET THE GPB IN THE CENTER THEN MARK 3 HOLES FOR THE WEDGE BOLTS THEN MARK 1" FROM BOTH ENDS (OF BASE SHOE) FOR THE CENTER OF THE CORE POCKET.

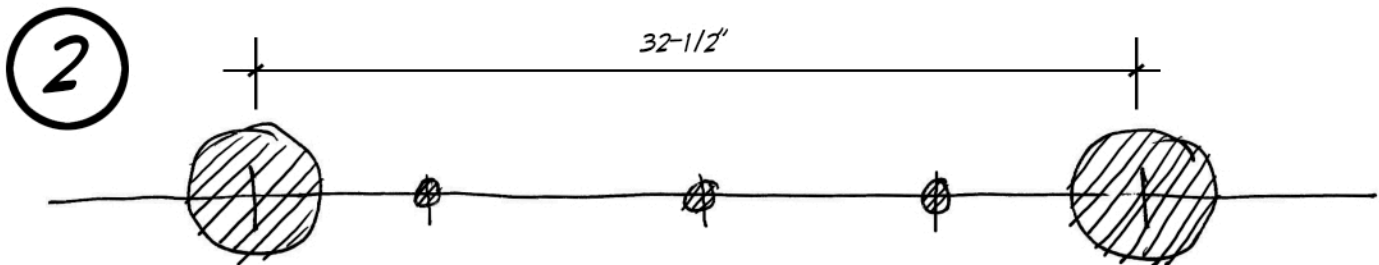

PREPARE TO DRILL

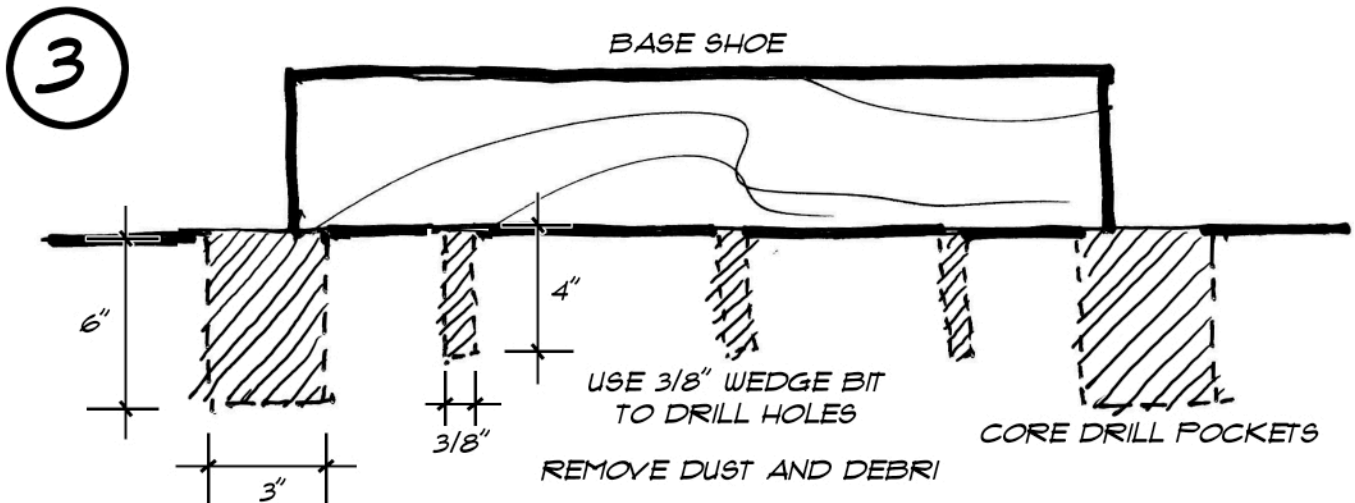

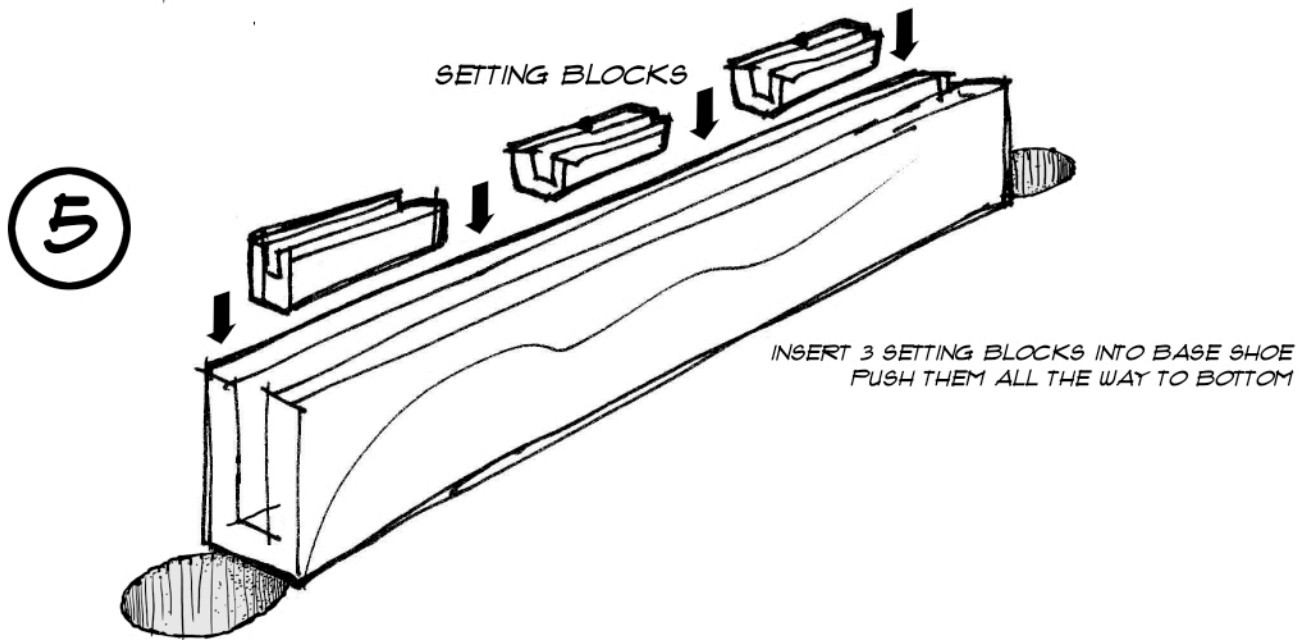
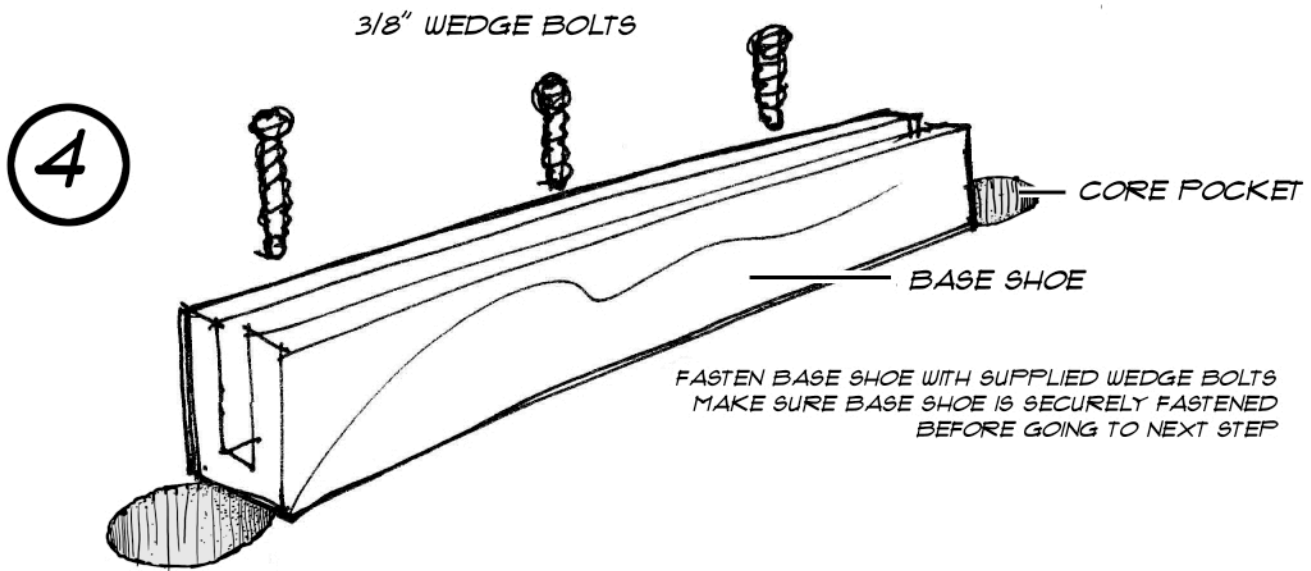

NOTE: AT THIS POINT YOU CAN ORDER THE GLASS PANELS FROM YOUR LOCAL GLASS VENDOR. YOUR GLASS VENDOR WILL PROVIDE THE U-CHANNEL THAT WILL SUPPORT THE PANEL ON TOP. PLEASE USE AN 1-1/2" OR WIDER U-CHANNEL FOR CEILING SUPPORT.

IMPORTANT: MAKE SURE THE CEILING HAS WOOD BACKING.

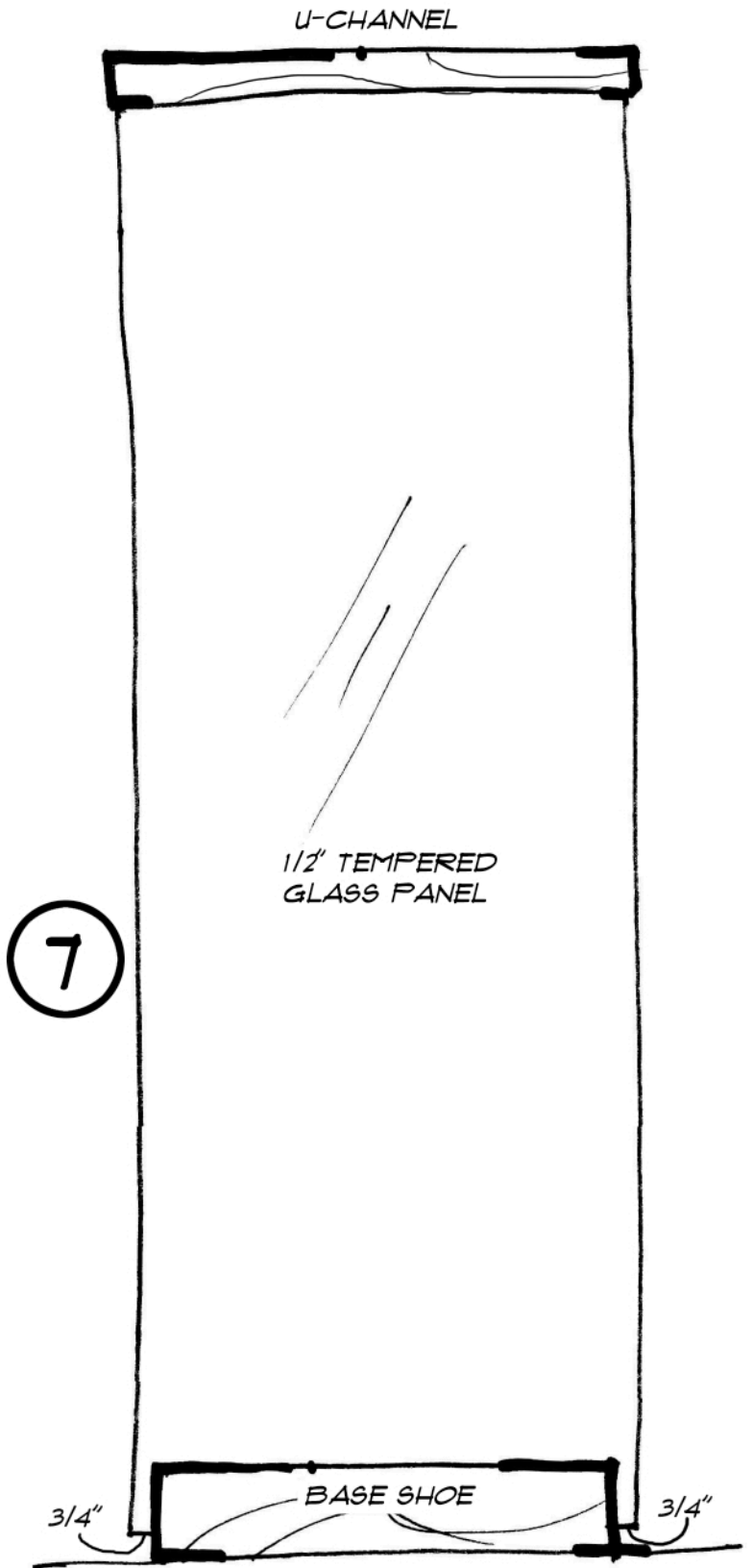
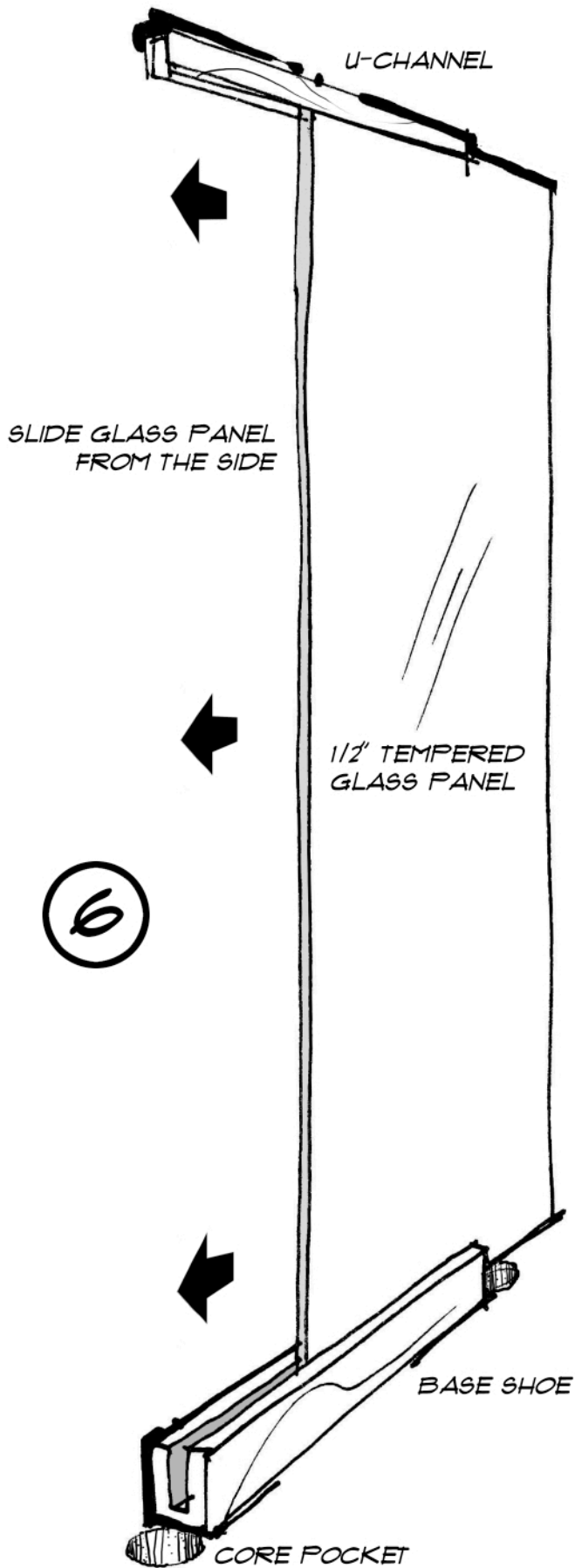

8

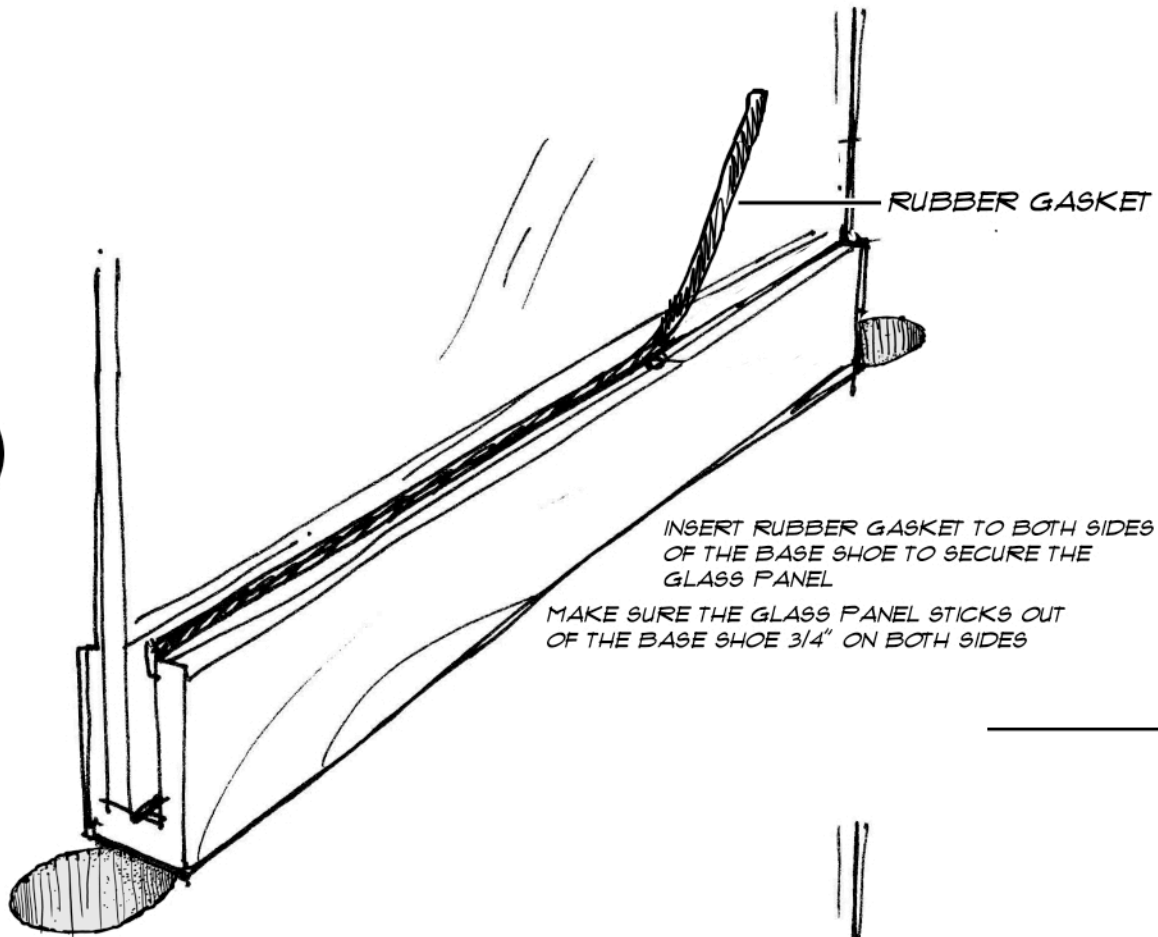

INSERT RUBBER GASKET TO BOTH SIDES
OF THE BASE SHOE TO SECURE THE
GLASS PANEL
MAKE SURE THE GLASS PANEL STICKS OUT
OF THE BASE SHOE 3/4" ON BOTH SIDES

9

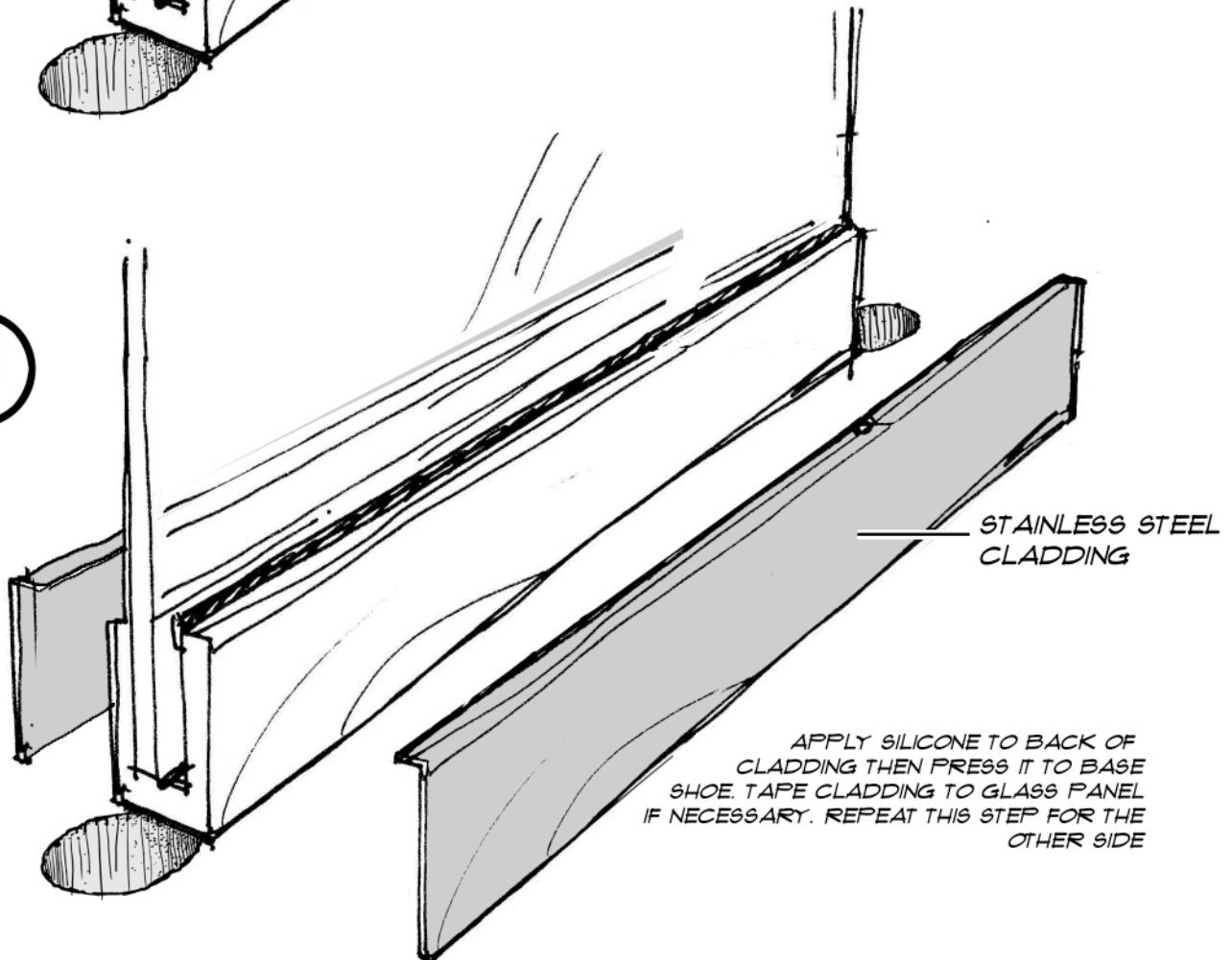

APPLY SILICONE TO BACK OF
CLADDING THEN PRESS IT TO BASE
SHOE. TAPE CLADDING TO GLASS PANEL
IF NECESSARY. REPEAT THIS STEP FOR THE
OTHER SIDE

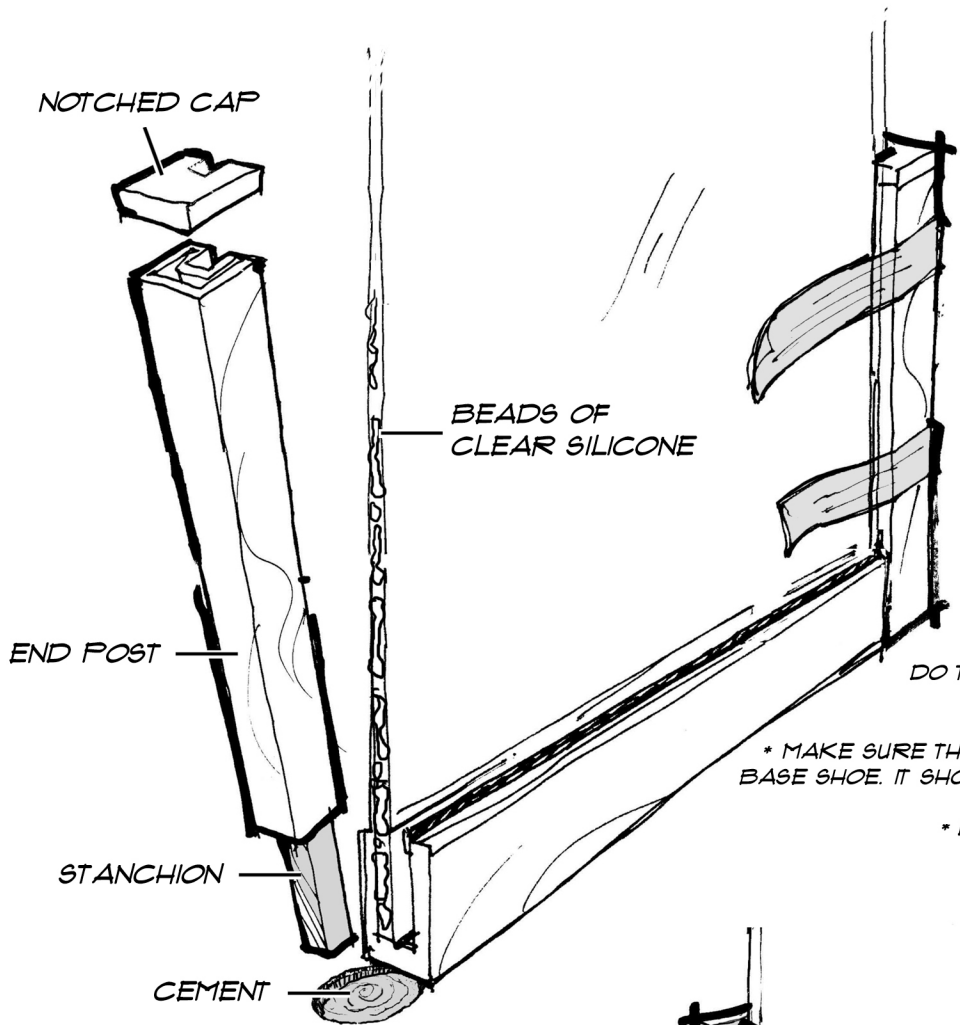

10

DUCT TAPE

- MATERIALS NEEDED
- * CEMENT
 - * DUCT TAPE
 - * CLEAR SILICONE FOR GLASS

DO NOT USE QUICK DRY CEMENT

DO THESE STEPS BEFORE YOU POUR CEMENT INTO THE CORE POCKET

- * MAKE SURE THAT THE GLASS PANEL IS IN THE MIDDLE OF BASE SHOE. IT SHOULD NOT STICK-OUT MORE THAN 3/4" FROM BASE SHOE ON BOTH ENDS.
- * DETACHED NOTCHED CAP FROM END POST
- * INSERT STANCHION INTO END POST

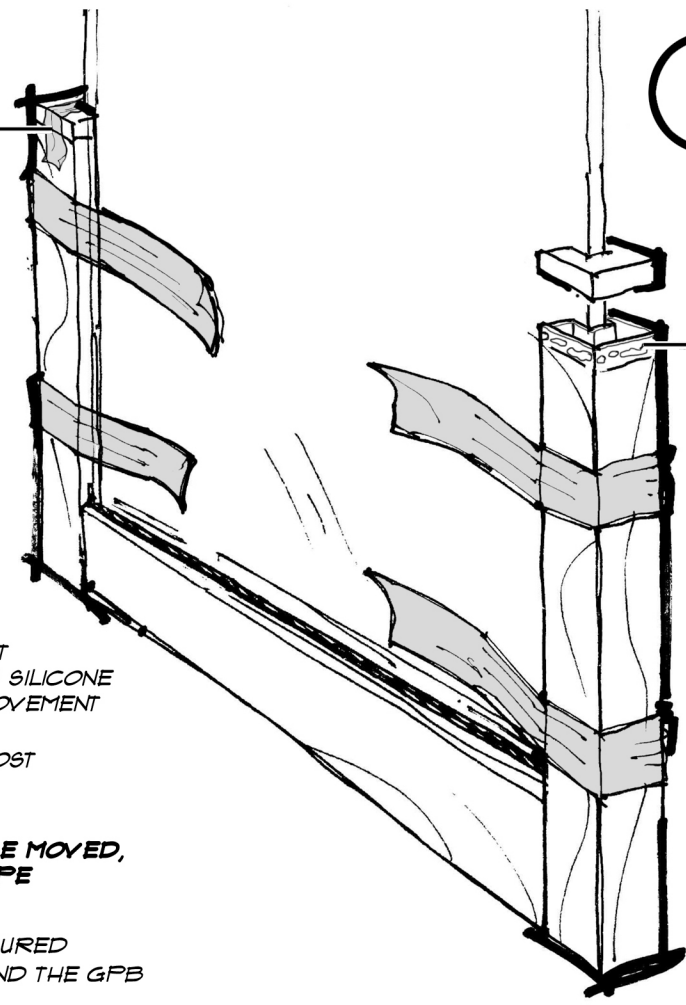

11

END POST INSTALLATION

- * APPLY BEADS OF SILICONE TO SIDE OF GLASS PANEL
- * WITH ONE HAND HOLDING THE END POST AND ONE HAND HOLDING THE STANCHION, EMBED (AT AN ANGLE) THE STANCHION INTO CORE POCKET. PUSH THE END POST UNTIL IT TOUCHES THE GLASS PANEL AND THE SHOE BASE.
- * CUT TWO PIECES OF DUCT TAPE THEN TAPE THE END POST AND GLASS PANEL TOGETHER.
- * APPLY BEADS OF SILICONE TO LIP OF END POST THEN SET THE NOTCHED CAP. WIPE OFF EXCESS SILICONE THEN TAPE THE CAP TO END POST TO AVOID MOVEMENT

REPEAT THE SAME STEPS ON THE OTHER END POST THEN CLEAN UP THE EXCESS CEMENT

TO GUARANTEE THAT THE END POST WILL NOT BE MOVED, WRAP THE TWO END POST WITH DUCT TAPE

LEAVE THE TAPE UNTIL THE CEMENT IS TOTALLY CURED PEEL OFF DUCT TAPE THEN CLEAN THE GLASS AND THE GPB